

# 350 P

Excavator



JOHN DEERE







350 P-TIER EXCAVATOR

## ***PUT MORE WORK WITHIN REACH***

Whether you're loading trucks, digging trenches, demolishing structures, or placing pipe, a P-Tier Excavator can make easy work out of your toughest tasks. Customer-inspired upgrades include improved front-joint durability, a redesigned hood that boosts serviceability and cooler access, and up to seven-percent better fuel economy compared to the 350G LC model. A camera array with LED-surround lighting and flexible grade-management solutions — including fully integrated SmartGrade™ — are welcome options. Our machines deliver what you've come to expect in mid-size John Deere excavators, so you can count on doing more.



## FEATURES



### Rugged resistance

Tungsten-carbide thermal coating creates an extremely wear-resistant surface to protect the bucket-to-arm joint. Standard mainframe and optional track-frame undercovers add an extra layer of defense.

### Control pattern

Designed to accommodate different operators with the simple flip of a lever, control pattern-change valve is standard instead of a field-kit option.

### Performance plus

Powerwise Plus™ technology delivers fuel-efficient power when you need it.

### Durable debris package

For work in environments with airborne debris, opt for our new debris package featuring an engine air centrifugal precleaner and a reversing electric variable-speed fan drive with selectable intervals and manual override.

### Powerful productivity

Three productivity modes allow you to choose the digging style that fits the job: **High-productivity** delivers more power and faster hydraulic response to move more material. **Power** delivers a balance of power, speed, and fuel economy for normal operation. **Economy** helps save fuel.



**UP TO 7%**  
BETTER FUEL  
ECONOMY COMPARED  
TO 350G LC



SET AUTO-IDLE  
TO 800 RPM TO  
**SAVE FUEL**

### Seeing is believing

Optional camera array with LED-surround lighting integrated into the main monitor work together to supplement 270-degree visibility of the area around the machine.

### Durable by design

Centralized lubrication at arm tip and improved front joint-bushing design relocate the grease-entry point to push contamination out from the center. New design simplifies routine greasing to boost joint life.

### Cool connections

Larger hood opening and individually serviceable coolers improve overall access around the front of the engine. Four bolts and a single electrical connector make fan maintenance quick and easy.

### Fuel saver

Electric, on-demand cooling fans ease engine load. In-line aftertreatment reduces system complexity and restriction. Larger front-piping diameter relieves hydraulic restriction, which combined lowers fuel consumption by up to seven percent compared to the 350G LC.

### At home in the cab

Sculpted mechanical-suspension high-back seat slides independent of the pilot-control console. Optional premium air-suspension leather seat is adjustable and heated/cooled. Ergonomically correct short-throw pilot levers provide smooth fingertip control. Push buttons in the right lever finesse auxiliary hydraulic flow for operating attachments. Wide expanse of front and side glass, narrow front cab posts, large overhead window, and numerous mirrors provide clear visibility.





## 350 P-TIER EXCAVATOR



***GOGRADE.DEERE.COM***  
**PROVIDES MOBILE-FRIENDLY  
SETUP & OPERATION**

### **It's smart to get good grades**

John Deere offers an economical way to adopt grade-management technology. Whether you're new to the game or want our most cutting-edge tech, there's a solution that will fit your needs. Choose 2D or 3D Excavator Grade Guidance or opt for fully integrated SmartGrade for 3D control including overdig protection and in-cab real-time distance to target. All grade-management solutions are factory ready and backed by your Deere dealer, including service, warranty, and financing.

### **Remote diagnostics and support**

To maximize uptime and lower costs, JDLink™ connectivity provides machine location, utilization data, and alerts to help you maximize productivity and efficiency. JDLink also enables John Deere Connected Support™. Dealers use Expert Alerts based on data from thousands of connected machines to proactively address conditions that may otherwise likely lead to downtime. Your dealer can also monitor machine health and leverage remote diagnostics and programming capability to further diagnose problems and even update machine software without a time-consuming trip to the jobsite.\*

\*Availability varies by region. Options not available in every country.





While general information, pictures, and descriptions are provided, some illustrations and text may include product options and accessories NOT AVAILABLE in all regions, and in some countries products and accessories may require modifications or additions to ensure compliance with the local regulations of those countries.

<b>Engine</b>	<b>350 P-TIER</b>		
	<b>Base engine for use in U.S., U.S. Territories, and Canada</b>		
Manufacturer and Model	John Deere PowerTech™ PSS 9.0 L		
Non-Road Emission Standard	EPA Final Tier 4/EU Stage IV		
Net Rated Power (ISO 9249)	202 kW (271 hp) at 1,900 rpm		
Cylinders	6		
Displacement	9.0 L (549 cu. in.)		
Off-Level Capacity	70% (35 deg.)		
Aspiration	Series turbocharged, air-to-air charge-air cooler		
<b>Cooling</b>	Electric, on-demand cooling fans standard; reversing electric variable-speed fan drive with selectable intervals and manual override available as part of optional debris package		
<b>Powertrain</b>	2-speed propel with automatic shift		
<b>Maximum Travel Speed</b>			
Low	3.2 km/h (2.0 mph)		
High	5.0 km/h (3.1 mph)		
Drawbar Pull	30 350 kg (66,900 lb.)		
<b>Hydraulics</b>	Open center, pilot controlled		
<b>Main Pumps</b>	2 variable-displacement pumps		
Maximum Rated Flow	288 L/m (76.1 gpm) x 2		
<b>Pilot Pump</b>	1 gear		
Maximum Rated Flow	30.2 L/m (8.0 gpm)		
Pressure Setting	3900 kPa (566 psi)		
<b>System Operating Pressure</b>			
Circuits			
Implement	34 300 kPa (4,975 psi)		
Travel	35 500 kPa (5,149 psi)		
Swing	33 300 kPa (4,830 psi)		
Power Boost	38 000 kPa (5,511 psi)		
<b>Controls</b>	Pilot levers, short stroke, low-effort hydraulic pilot controls with shutoff lever		
<b>Cylinders</b>	<i>Bore</i>	<i>Rod Diameter</i>	<i>Stroke</i>
<b>Boom (2)</b>	145 mm (5.7 in.)	100 mm (3.9 in.)	1520 mm (59.8 in.)
<b>Arm (1)</b>	170 mm (6.7 in.)	115 mm (4.5 in.)	1740 mm (68.5 in.)
<b>Bucket (1)</b>	140 mm (5.5 in.)	95 mm (3.7 in.)	1250 mm (49.2 in.)
<b>Mass-Excavating (ME) Bucket (1)</b>	145 mm (5.7 in.)	95 mm (3.7 in.)	1250 mm (49.2 in.)
<b>Electrical</b>	Number of Batteries (12 volt) 2		
Battery Capacity	1,400 CCA		
Alternator Rating	100 amp		
Work Lights	2 halogen (1 mounted on boom, 1 on frame)		
<b>Undercarriage</b>	<b>Rollers (each side)</b>		
Carrier	2		
Track	8		
Shoes, Triple Semi-Grousers (each side)	48		
<b>Track</b>	Adjustment Hydraulic		
Guides	3 per side		
Chain	Sealed and lubricated		

## 350 P-TIER EXCAVATOR SPECIFICATIONS

# 350

# P

While general information, pictures, and descriptions are provided, some illustrations and text may include product options and accessories NOT AVAILABLE in all regions, and in some countries products and accessories may require modifications or additions to ensure compliance with the local regulations of those countries.

<b>Ground Pressure</b>	<b>350 P-TIER</b>
800-mm (32 in.) Triple Semi-Grouser Shoes	50.1 kPa (7.27 psi)

<b>Swing Mechanism</b>	
<b>Swing</b>	
Speed	10.7 rpm
Torque	120 000 Nm (88,500 lb.-ft.)

<b>Serviceability</b>			
<b>Refill Capacities</b>		<b>Refill Capacities (continued)</b>	
Fuel Tank	628 L (166 gal.)	Hydraulic System	290 L (77 gal.)
Diesel Exhaust Fluid (DEF) Tank	35 L (9.3 gal.)	Swing Drive	11.8 L (12.5 qt.)
Cooling System	39.7 L (10.5 gal.)	Gearbox	
Engine Oil With Filter	27 L (7.2 gal.)	Propel (each)	8.5 L (9.0 qt.)
Hydraulic Tank	193 L (51 gal.)	Pump Drive	1.1 L (1.2 qt.)

<b>Operating Weights</b>	
With full fuel tank; 79-kg (175 lb.) operator; 1.76-m <sup>3</sup> (2.3 cu. yd.), 1372-mm (54 in.), 1532-kg (3,377 lb.) heavy-duty (HD) bucket; 4.0-m (13 ft. 1 in.) arm; 6928-kg (15,274 lb.) counterweight; and 800-mm (32 in.) triple semi-grouser shoes	
Operating Weight	36 734 kg (80,985 lb.)

<b>Component Weights</b>	
Undercarriage With 800-mm (32 in.) Triple Semi-Grouser Shoes	12 750 kg (28,100 lb.)
6.4-m (21 ft. 0 in.) One-Piece Boom (with arm cylinder)	3080 kg (6,790 lb.)
<b>Arm With Bucket Cylinder and Linkage</b>	
3.2 m (10 ft. 6 in.)	1802 kg (3,973 lb.)
4.0 m (13 ft. 1 in.)	1985 kg (4,376 lb.)
Boom-Lift Cylinders (2), Total Weight	624 kg (1,376 lb.)
1.76-m <sup>3</sup> (2.3 cu. yd.), 1372-mm (54 in.) HD Bucket	1532 kg (3,377 lb.)
Counterweight, Standard	6928 kg (15,274 lb.)

<b>Operating Dimensions</b>			
	<i>3.2 m (10 ft. 6 in.) / 6.4-m (21 ft. 0 in.) Boom Length</i>	<i>4.0 m (13 ft. 1 in.) / 6.4-m (21 ft. 0 in.) Boom Length</i>	
<b>Arm Length</b>			
Arm Digging Force			
SAE	177.0 kN (39,791 lb.)	152.6 kN (34,314 lb.)	
ISO	185.0 kN (41,590 lb.)	159.0 kN (35,745 lb.)	
Bucket Digging Force			
SAE	214.0 kN (48,109 lb.)	225.2 kN (50,628 lb.)	
ISO	246.0 kN (55,303 lb.)	246.0 kN (55,303 lb.)	
<b>A</b> Maximum Reach	11.10 m (36 ft. 5 in.)	11.86 m (38 ft. 11 in.)	
<b>A<sup>1</sup></b> Maximum Reach at Ground Level	10.89 m (35 ft. 9 in.)	11.67 m (38 ft. 3 in.)	
<b>B</b> Maximum Digging Depth	7.38 m (24 ft. 3 in.)	8.18 m (26 ft. 10 in.)	
<b>B<sup>1</sup></b> Maximum Digging Depth at 2.44-m (8 ft. 0 in.) Flat Bottom	7.21 m (23 ft. 8 in.)	8.04 m (26 ft. 5 in.)	
<b>C</b> Maximum Cutting Height	10.36 m (34 ft. 0 in.)	10.75 m (35 ft. 3 in.)	
<b>D</b> Maximum Dumping Height	7.24 m (23 ft. 9 in.)	7.63 m (25 ft. 0 in.)	
<b>E</b> Minimum Swing Radius	4.46 m (14 ft. 8 in.)	4.47 m (14 ft. 8 in.)	
<b>F</b> Maximum Vertical Wall	6.42 m (21 ft. 1 in.)	7.27 m (23 ft. 10 in.)	

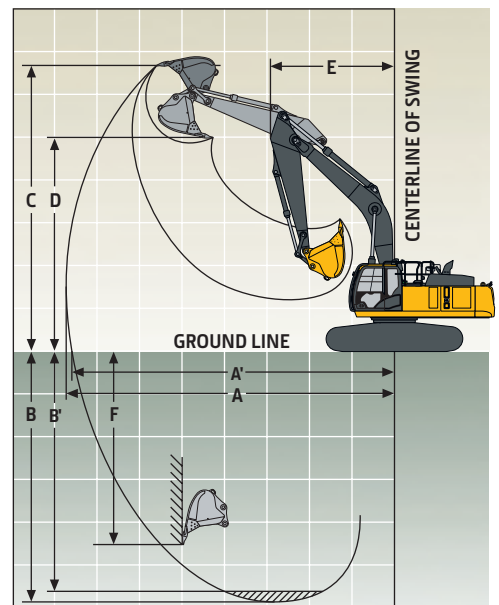

## Bucket Selection Guide\*

## 350 P-TIER

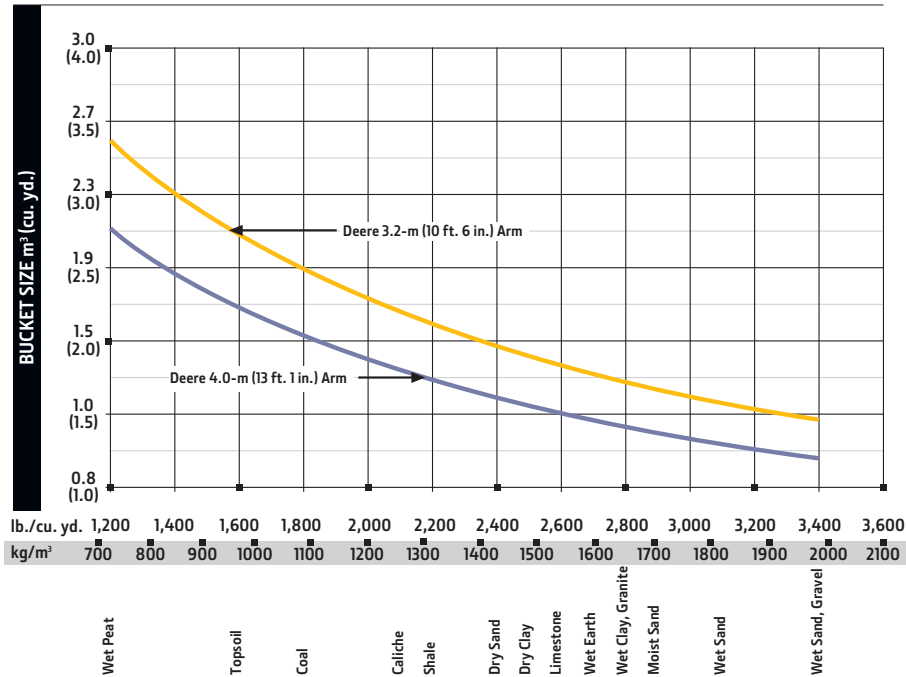

\*Contact your John Deere dealer for optimum bucket and attachment selections. These recommendations are for general conditions and average use. Does not include optional equipment such as thumbs or couplers. Larger buckets may be possible when using light materials, for flat and level operations, less compacted materials, and volume loading applications such as mass-excavation applications in ideal conditions. Smaller buckets are recommended for adverse conditions such as off-level applications, rocks, and uneven surfaces. Bucket capacity indicated is SAE heaped.

## Additional equipment

Key: ● Standard ▲ Optional or special  
See your John Deere dealer for further information.

### 350 P Engine

- Auto-idle system
- Automatic belt-tension device
- Batteries (2 – 12 volt)
- Coolant recovery tank
- Dual-element dry-type air filter
- Electronic engine control
- Enclosed fan guard (conforms to SAE J1308)
- Engine coolant to -37 deg. C (-34 deg. F)
- Programmable auto shutdown
- Fuel filter with water separator
- Fuel shutoff valve
- Full-flow oil filter
- Turbocharger with charge air cooler
- Electric, on-demand cooling fans
- 500-hour engine-oil-change interval
- 70% (35 deg.) off-level capability
- Engine-oil-sampling valve
- ▲ Chrome exhaust stack
- ▲ Electric ether starting aid

### 350 P Engine (continued)

- ▲ Reversing electric variable-speed fan drive with selectable intervals and manual override (available only as part of debris package)
- ▲ Engine coolant heater
- ▲ Engine air precleaner
- ▲ Severe-duty fuel filter

### Hydraulic System

- Reduced-drift valve for boom down, arm in
- Auxiliary hydraulic valve section
- Spring-applied, hydraulically released automatic swing brake
- Auxiliary hydraulic-flow adjustments through monitor
- Auto power lift
- 5,000-hour hydraulic-oil-change interval
- Hydraulic-oil-sampling valve
- Control pattern-change valve
- Powerwise Plus™ hydraulic-management system

### 350 P Hydraulic System (continued)

- ▲ Auxiliary hydraulics with combination piping
- ▲ Auxiliary pilot and electric controls
- ▲ Hydraulic filter restriction indicator kit
- ▲ Load-lowering control / Anti-drift device
- ▲ Single-pedal propel control
- ▲ Dual pump-flow combiner
- ▲ High-flow auxiliary hydraulic lines with dual stop valves

### Undercarriage

- Planetary drive with axial piston motors
- Propel motor shields
- Spring-applied, hydraulically released automatic propel brake
- Track guides, front idler and 3 additional
- 2-speed propel with automatic shift
- Upper carrier rollers (2)
- Sealed and lubricated track chain
- Heavy-duty undercover



# Additional equipment *(cont.)*

Key: ● Standard ▲ Optional or special  
See your John Deere dealer for further information.

## 350 P Undercarriage *(continued)*

- Triple semi-grouser shoes, 700 mm (28 in.)
- Single-bar shoes, 700-mm (28 in.) Heavy Duty (HD)
- Triple semi-grouser shoes, 800 mm (32 in.)
- ▲ Undercarriage frame opening guard

### Upperstructure

- Right-hand and left-hand mirrors
- Vandal locks with ignition key: Cab door / Service doors / Toolbox
- Debris screen in side panel
- Remote-mounted engine oil and fuel filters

### Front Attachments

- Centralized lubrication system
- Dirt seals on all bucket pins
- Less boom and arm
- Oil-impregnated bushings
- Reinforced resin thrust plates
- Tungsten carbide thermal coating on arm-to-bucket joint
- ▲ Arm, 3.2 m (10 ft. 6 in.)
- ▲ Arm, 4.0 m (13 ft. 1 in.)
- ▲ Attachment quick-couplers
- ▲ Boom cylinder with plumbing to main-frame for less boom and arm
- ▲ Buckets: Heavy duty / Side cutters and teeth
- ▲ Material clamps

### Operator's Station

- Adjustable independent-control positions (levers-to-seat, seat-to-pedals)
- AM/FM radio
- Auto climate control/air conditioner/heater/pressurizer
- Built-in Operator's Manual storage compartment and manual
- Cell-phone power outlet, 12 volt, 60 watt, 5 amp
- Coat hook
- Retractable seat belt, 76 mm (3 in.) (conforms to SAE J368)

## 350 P Operator's Station *(continued)*

- Floor mat
- Front windshield wiper with intermittent speeds
- Gauges (illuminated): Diesel Exhaust Fluid (DEF) / Engine coolant / Fuel
- Horn, electric
- Hourmeter, electric
- Hydraulic shutoff lever, all controls
- Hydraulic warm-up control
- Interior light
- Large cup holder
- Machine Information Center (MIC)
- Mode selectors (illuminated): Power modes (3) / Travel modes (2 with automatic shift) / Work mode (1)
- Multifunction, color LCD monitor with: Diagnostic capability / Multiple-language capabilities / Maintenance tracking / Clock / System monitoring with alarm features: Auto-idle indicator, engine air cleaner restriction indicator light, engine check, engine coolant temperature indicator light with audible alarm, engine oil pressure indicator light with audible alarm, low-alternator-charge indicator light, low-fuel indicator light, low DEF indication with audible alarm, fault code alert indicator, fuel-rate display, wiper-mode indicator, work-lights-on indicator, and work-mode indicator
- Motion alarm with cancel switch (conforms to SAE J994)
- Power-boost switch on right console lever
- Auxiliary hydraulic control switches in right console lever
- SAE 2-lever control pattern
- Tinted glass
- Transparent tinted overhead hatch
- Hot/cold beverage compartment
- USB charging port
- ▲ Hydraulic oil filter restriction indicator light

## 350 P Operator's Station *(continued)*

- ▲ Protection screens for cab front, rear, and side
- ▲ Window vandal-protection covers
- ▲ In-monitor adjustable flow and pressure auxiliary hydraulics with auxiliary function lever (AFL)

### Factory-Integrated Grade Control

- ▲ 2D Guidance
- ▲ 3D Guidance
- ▲ SmartGrade™ Ready 2D control
- ▲ SmartGrade 3D control

### Electrical

- 100-amp alternator
- Blade-type multi-fused circuits
- Positive-terminal battery covers
- JDLink™ wireless communication system (available in specific countries; see your dealer for details)
- Rearview camera
- ▲ Cab extension wiring harness

### Lights

- LED work lights

### Trim Packages

- **Level 1:** Mechanical seat and standard front LED worklights
- ▲ **Level 2:** Heated, air-suspension seat and standard front LED worklights
- ▲ **Level 3:** Heated, air-suspension seat, deluxe front LED worklights, and chrome exhaust
- ▲ **Level 4:** Premium-leather, thermal-heating, and active-cooling seat; deluxe front LED worklights; and chrome exhaust

### Application Packages

- ▲ **Cold-weather package:** Engine-block heater and ether start aid
- ▲ **Debris package:** Engine air centrifugal precleaner, reversing electric variable-speed fan drive with selectable intervals and manual override (for use in airborne-debris environments)

While general information, pictures, and descriptions are provided, some illustrations and text may include product options and accessories NOT AVAILABLE in all regions, and in some countries products and accessories may require modifications or additions to ensure compliance with the local regulations of those countries.

Net engine power is with standard equipment including air cleaner, exhaust system, alternator, and cooling fan, at test conditions specified per ISO 9249. No derating is required up to 3050-m (10,000 ft.) altitude. Specifications and design subject to change without notice. Wherever applicable, specifications are in accordance with SAE standards. Except where otherwise noted, these specifications are based on a unit with 1372-mm (54 in.) heavy-duty (HD) bucket, 6928-kg (15,274 lb.) counterweight, 800-mm (32 in.) triple semi-grouser shoes. Full fuel tank, and 79-kg (175 lb.) operator.



ME350PAU (22-02)



**JOHN DEERE**